



Econoflow 84 Series

Users Manual

SLS Econoflow 84

Contents

General Information	2
General Safety Summary	3-5
Specifications.....	6
Signs and Symbols	6
Technical Specifications	6
Overview of the Infusion Pump	7-9
Prepare for the Infusion	10
Start Up.....	11-12
Quick Operatng Instructions	13
Operation Settings and Procedures	14-23
Select Presets	15
Preset Program	15
Language Setting	16
Date Format	17
Set Clock.....	17
Date on/off.....	18
ML or Drop Seting.....	18-19
Adj. I.V. Set (Accuracy Calibration).....	20-21
Occlu. Level (Occlusion Level).....	22
Factory Reset	23
Bolus Function	24-25
Purge Function.....	26
Alarm Messages	27-31
Start Reminder Alarm	27
Door Open Alarm	27
Air in Line Alarm	28
Occlusion in Line	28
Empty Alarm.....	29
Complete Alarm	29
Low Battery Alarm.....	30
Drive Mechanism Error	31
Limited Warranty.....	32

SLS Econoflow 84

General Information

Before using the pump, be sure to read carefully and understand all sections of this user manual. Failure to read and understand the instructions may lead to misuse of the pump, which could result in harm to the subject.

HEADINGS USED IN THIS MANUAL

This guide contains warnings, precautions, and important information to help call your attention to the most important safety and operational aspects of the pump. To help identify these items when they occur in the text, they are shown using the following headings:

WARNING

Statements that describe serious adverse reactions and potential safety hazards.

PRECAUTION

Statements that call attention to information regarding any special care to be exercised by the practitioner for the safe and effective use of the device.

IMPORTANT

Statements that call attention to additional significant information about the device or a procedure.

SLS Econoflow 84

General Safety Summary

IMPORTANT: User should read this entire manual before operating this volumetric infusion pump.

WARNINGS OVERVIEW

Critical! Explosion hazard. Do not use in the presence of flammable solvents!

WARNINGS:

- 1) Do not use a pump, infusion set, or accessory that shows any sign of damage.
- 2) The pump does not detect air bubbles or occlusion when priming. When priming, do not connect the infusion set to the patient.
- 3) Do not submerge this pump in water or other liquid.
- 4) Before starting an infusion, with the iv set installed in the pump and the flow-protection clamp open, verify that there is no flow of fluid from the infusion set. Also check that the programmed information is correct.
- 5) Close the infusion set's flow-protection clamp before and after removing the infusion set from the pump to prevent unrestricted flow.
- 6) Before connecting the iv set to the patient, user must prime the infusion set to prevent air to the patient.
- 7) To prevent electric hazards, unplug the pump before cleaning. Do not spray cleansers into the iv set or power cord receptacles. Do not submerge the pump in any liquid.
- 8) Do not use any infusion set if its packaging appears to be damaged or opened.

PRECAUTIONS OVERVIEW

- 1) Do not connect i.v set used by pump to unspecified/unauthorized gravity-controlled i.v set, as this may affect the accuracy of infusion and may trigger false alarms, which could result serious injury to the patient. Contact your distributor for the authorized pump use iv sets with the appropriate adjustment on the pump menu settings to work this infusion pump.
- 2) While pump is using ac power, please ensure the power outlet is properly grounded.
- 3) Disposable infusion sets used in the pump should comply with the government regulations.
- 4) Used infusion sets should be stored in a safe place, and disposed according to regulations.
- 5) The circuit diagram and parts list will only be provided to manufacturer assigned technicians.

SLS Econoflow 84

Warnings and Precautions (Continued)

- 6) The accessories include a drop sensor. The drop sensor is an accessory used to detect whether there is fluid left in the reservoir. Reminder: if the detector is not used, please unplug the detector from the pump; otherwise the completion and occlusion alarms will be triggered simultaneously.
- 7) If you choose to use the drop sensor, install with care. The detector is vertical to the reservoir bottle. Solution surface has to be below the mid-line of the dripping chamber. If "complete" and "occlusion" alarms are set off right after the pump starts running, check the connection sockets at the back of the pump to see whether the detector has been installed properly or not.
- 8) When relocating the pump, please avoid an excessive swing of fluid bag (and drip detector).
- 9) The pump can be used on a horizontal platform or on the iv stand with the iv pole clamp. Before securing the pump on the iv pole, please make sure that the iv stand is solid vertically and won't fall with the weight of the pump.
- 10) There may be a low battery alarm when the pump is powered on with battery power for the first time after a long period of time. When the low battery alarm sets off, the pump has to be connected to the electrical outlet to continue to operate. The pump can operate with ac power and charge the batteries at the same time. After a continuous charge of 8 hours, the battery can support running at a rate of 25 ml/h up to 3 hours.
- 11) Periodically the pump and drop sensor need to be cleaned. Use a damp (not wet) cloth or sponge; gently wipe off the shell and control panel of pump. Do not immerse pump or power cable into water or other cleaning solutions.
- 12) To ensure the battery works well within its life-span, operate with battery power occasionally to examine whether the battery works properly. If the battery is not used for a period of time, charge the battery at least every three months.
- 13) Disconnect the pump with ac power while changing the fuse.
- 14) This infusion pump is not intended to replace trained personnel in the supervision of infusions.
- 15) Only authorized service personnel should repair this pump. Manufacturer assumes no responsibility for incidents that occur if the pump is not repaired according to manufacturer-authorized procedures.
- 16) Carefully read and follow the infusion set instructions.
- 17) Only approved accessories should be used with this pump
- 18) When infusing through a central line catheter, luer lock connectors should be used.

SLS Econoflow 84

Warnings and Precautions (Continued)

- 19) Do not clean, disinfect or sterilize any part of the pump with ethylene oxide gas or by autoclaving. This may damage the pump and will void the warranty; disinfect the pump's external parts only, using approved cleansers or disinfectants.
- 20) These chemicals may damage the pump's front panel: acetaldehyde, acetone, ammonia, benzene, hydroxytoluene, methylene chloride, or ozone. Do not use those chemicals or cleansers containing n-alkyldimethylbenzylammonium chloride.
- 21) Portable and mobile rf communications equipment can affect this infusion pump. If this pump does not appear to be working normally try to relocate or reorient the pump.
- 22) The use of non-recommended accessories may result in increased emc emissions or decreased emc immunity of this infusion pump.
- 23) When using this infusion pump with life-sustaining medications, ensure there are backup pumps and infusion sets.
- 24) The tube placed on peristaltic part of the pump could be altered after 24 hours running; it's suggested replacing the iv set or change the tube area placed on the pump's peristaltic part to ensure accurate infusion.



CAUTION
Refer to Manual



Protective Ground
Terminal

SLS Econoflow 84

Specifications

SIGNS AND SYMBOLS

Category	Type I Internal Power Supplied
Type of Protection Against Electric Shock	Type BF
Mode of Operation	Continuous
Degree of Protection Against Ingress of Fluids	Drip-Proof IPX1
Application:	I.V infusion set

TECHNICAL SPECIFICATIONS

ENVIRONMENT :

Condition	Operating	Transportation / Storage
Relative humidity (non-condensing)	<80 %	<93 %
Temperature	10oc to + 30oc 50of to + 86of	-10oc to + 55oc 14of to + 131of
Atmospheric	700 to 1060 hpa	500 to 1060 hpa

SLS Econoflow 84

Overview of Infusion Pump

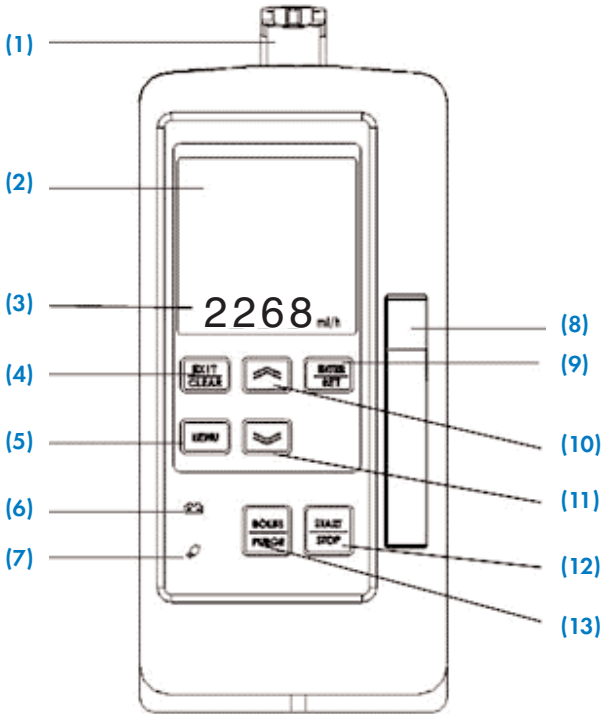

- 1) **Visual Alarm:** The light will flash with sound if the alarm are triggered
- 2) **Display Screen:** Display pump and infusion status
- 3) **LED Rate Display:** Returns to previous screen; zeros the displayed value during programming, erases that last digit during programming
- 4) **EXIT/CLEAR Button:** Returns to previous screen; zeros the displayed value during programming, erases the last digit during programming
- 5) **MENU:** Go to menu options
- 6) **Battery Indicator:** The battery indicator in red means that the internal battery is being used
- 7) **AC Power Indicator:** The battery indicator in RED means that the internal battery is being used
- 8) **Door Handle Open:** Push the top part of the handle then pull handle to open the door; slide down the handle to close the door.
- 9) **ENTER/SET Button:** Confirms selecting and setting
- 10) **Up Arrow:** Scrolls up through options
- 11) **Down Arrow:** Scrolls down through options
- 12) **BOLUS/PURGE Button:** Hold to enter BOLUS setup when the pump is running; hold to start PURGE when the pump is stopped
- 13) **START/STOP Button:** Starts infusion; stops infusion; silence an alarm condition

SLS Econoflow 84

Overview of Infusion Pump (Continued)

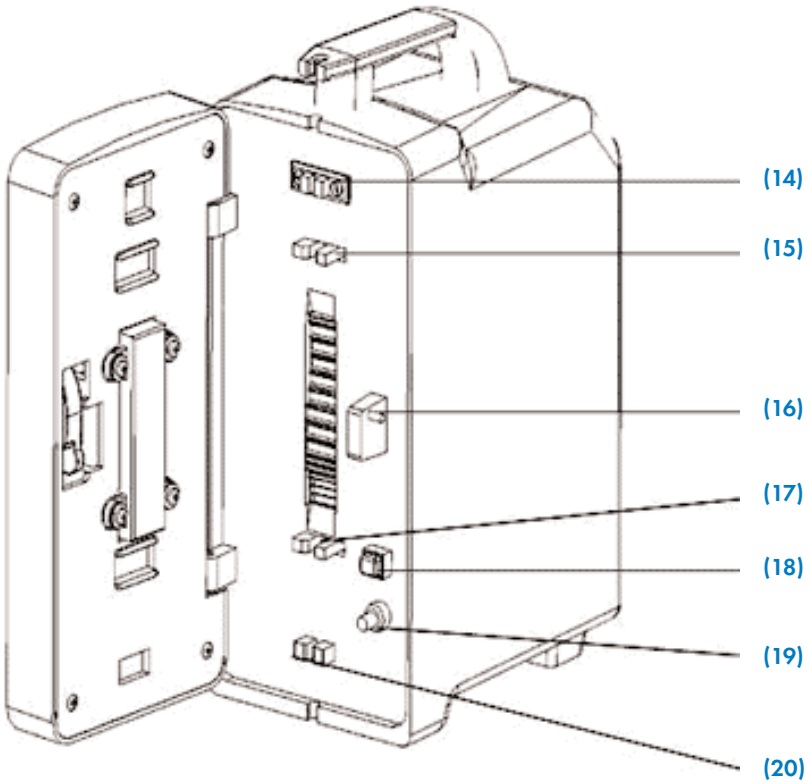

- 14) **Air Director:** Infrared air detector detects air in line
- 15) **Up Tube Clamp:** Guides the Administration Set and detects the downstream occlusion
- 16) **Door Holder:** Holds the door
- 17) **Down Tube Clamp / Occlusion Sensor:** Guides the Administration Set and detects the downstream occlusion in the line
- 18) **Tube Clamp Opener:** Push to open the down clamp
- 19) **Door Open Detector:** Closes the down tube clamp to prevent free flow when the door is open
- 20) **Tube Retainer:** Guides the Administration Set

SLS Econoflow 84

Overview of Infusion Pump (Continued)

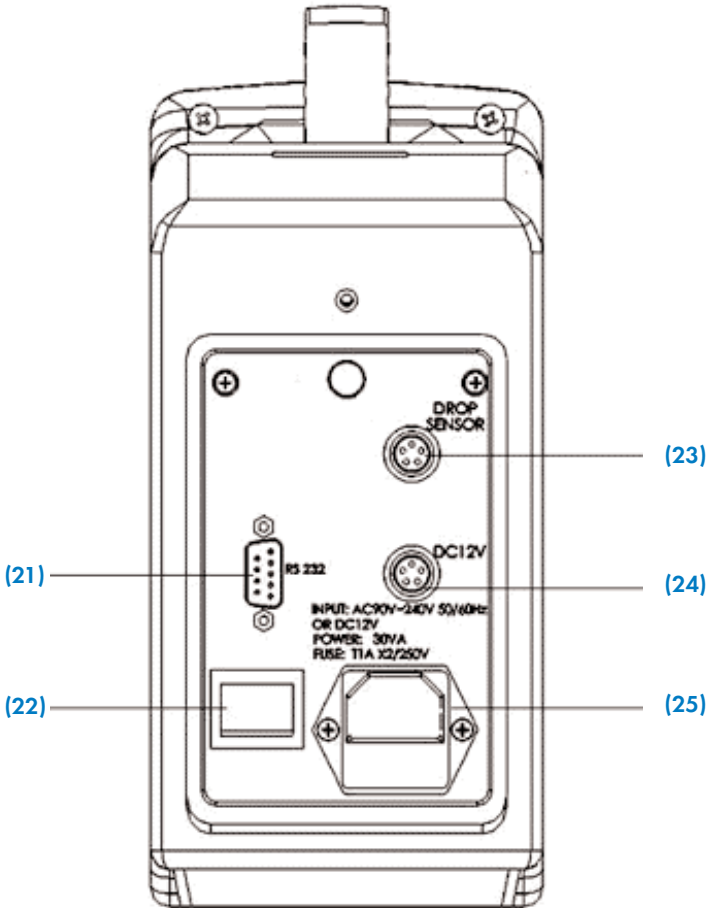

- | | |
|--|--|
| 21) RS 232 Data Port: For data communication | 24) DC 12V Plug: Plug DC 12V car charger adapter (optional) |
| 22) Power Switch: Main ON/OFF power switch | 25) Main Power Plug: Wall-to-Pump power cord (included) |
| 23) Drop Sensor Plug: Plug drop sensor (included) | |

SLS Econoflow 84

Prepare for the Infusion

IMPORTANT: Infusion pump can be secured on the IV pole by IV clamp (included) as picture 1 or other accessories.

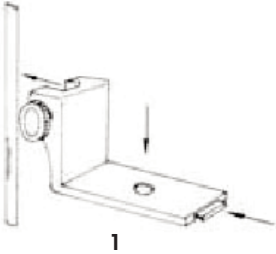

- 1) Prepare fluid bag and sterile disposable infusion device fluid according to operation procedures, squeeze drip chamber of IV set to fill up to line.

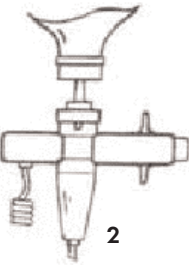

- 2) Connect drop sensor (included) to infusion pump and position it horizontally on the drip chamber above the fluid line as in picture 2.

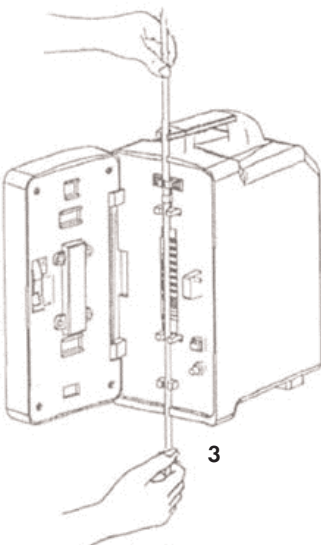

- 3) Open the door and press 'Tube Clamp opener' to open the "Down Tube Clamp".
- 4) Guide infusion tube through "Air Detector", "Up Tube Clamp", "Down Tube Clamp" and "Tube Retainer" as in picture 3. The tube clamp will be automatically closed while the door is closed.

SLS Econoflow 84

Start Up

IMPORTANT: For the first time use, user **MUST** read this manual carefully.

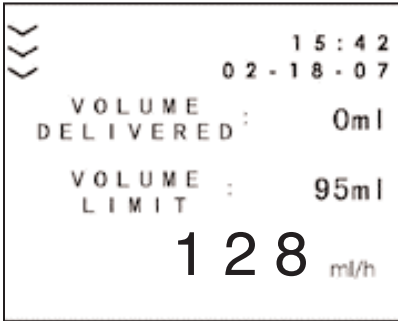

Screen 1

- 1) Connect the power cord firmly to the pump and electrical outlet to charge internal batteries. Pump can still be used while batteries are charging. During the operations, if the power cord is disconnected, pump will automatically switch to internal battery power and will keep a continuous normal operation. Batteries charged over 8 hours can support continuous operation for over 3 hours at 25ml/h infusion rate.
- 2) Pump has self-diagnostic function. The pump will initiate a self-diagnostic program to go through key components every time the pump is turned on. After self-diagnosis is completed successfully, user will see a welcome screen with company logo, followed by the main screen (screen 1). Then this pump is ready for use.

SLS Econoflow 84

Start Up (Continued)

IF THE SELF-DIAGNOSIS FAILS:



Screen 2

- 1) **Malfunction of Air-in-Line detecting system: AIR ALARM SYS. ERROR** (screen 2) will appear. Pump cannot be used until it is inspected by authorized service personnel.

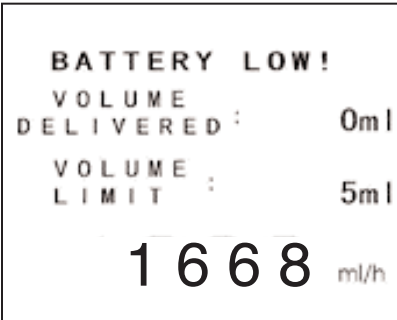











Screen 3

- 2) **Low Battery alarm at initialization: BATTERY LOW!** (screen 3) will appear. Pump has to be connected to electrical outlet before continuing to operate.

SLS Econoflow 84

Quick Operating Instructions



- 1) Press ON/OFF switch on the back of the pump to turn on the device.
- 2) Close roller clamp on set, spike and hang fluid container. Fill drip chamber to fill line.
- 3) Open roller clamp to fill all the set with fluid. Close roller clamp.
- 4) Open door, install set. Close door. Open roller clamp.
- 5) Press  once to enter the infusion rate setting screen, press or hold  or  to set desired infusion rate. Press  once to confirm the desired rate and jump to volume setting.
- 6) Press or hold  or  to set desired volume to be infused. Press  to confirm the setting and return to the main screen.
- 7) Attach the infusion set to vein-puncture device.
- 8) Hold  to prime the infusion set.
- 9) Connect the vein-puncture device to the patient. Press  to begin infusion.
- 10) To stop infusion, press .
- 11) To restart or clear the total infused volume, press ON/OFF switch on the back of the pump to restart the pump (minimum 3 seconds interval).

ALARMS

- To silent alarm, press .
- Once Flash light and audio alarm is triggered, please note the alarm messages and correct cause of alarm on the screen.

SLS Econoflow 84

Operation Settings and Procedures

After the self-diagnosis is completed successfully, press **MENU** to enter MODE SETTING (screen 4-7). Press UP Arrow  or DOWN Arrow  to select from 0-9 different settings.

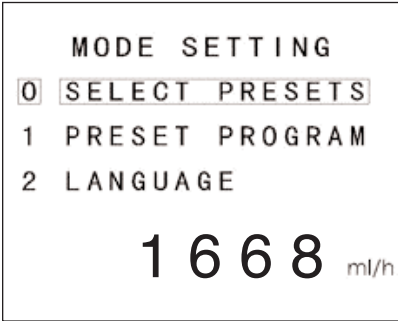

Screen 4

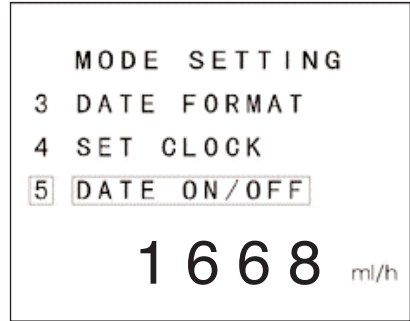

Screen 5

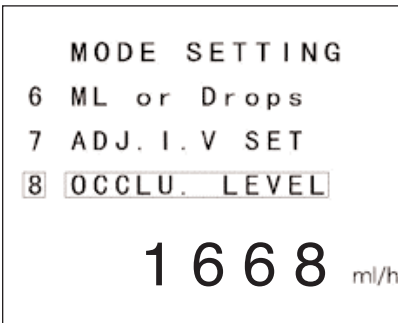

Screen 6

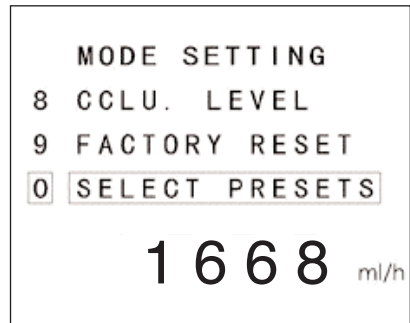

Screen 7

- 0 **SELECT PRESETS** – select presented frequently used rate and volume combinations stored in the pump memory.
- 1 **PRESET PROGRAM** – input and store frequently used data in one of ten memories..
- 2 **LANGUAGE** – select preferred operation language.
- 3 **DATE FORMAT** – select preferred date display format.
- 4 **SET CLOCK** – set real time clock.
- 5 **DATE ON/OFF** – turn on or turn off the date display on main screen.
- 6 **ML OR DROPS** – select preferred flow rate unit
- 7 **ADJ. I.V SET** – calibrate the pump to ensure the accuracy
- 8 **OCCLU. LEVEL** – adjust sensitivity of Occlusion Alarm for 3 different pressure levels.
- 9 **FACTORY RESET** – restore to original factory settings.

SLS Econoflow 84

Operation Settings and Procedures (Continued)

1. SELECT PRESETS

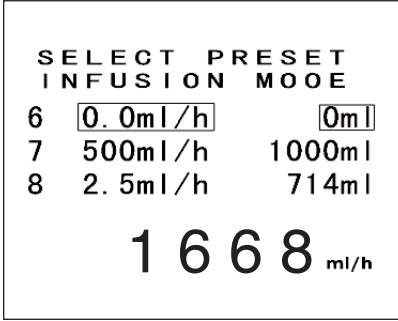

Screen 8

- 1) Press **MENU** to enter MODE SETTING status.
- 2) Select item No.0 SELECT PRESETS;
- 3) Press **ENTER SET** to enter (screen 8).
- 4) Use **▲** or **▼** to select data memory from 0-9 for preferred infusion mode.
- 5) Press **ENTER SET** to confirm selection, and then return to main screen.
- 6) If preset infusion mode is not selected, press **EXIT CLEAR** to return to main screen.

2. PRESET PROGRAM

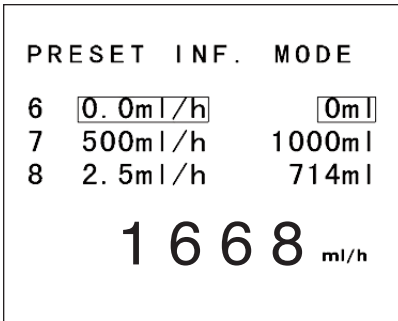

Screen 9

- 1) Press **MENU** to enter MODE SETTING status.
- 2) Press **▲** or **▼** to select item No.1 **PRESET PROGRAM**
- 3) Press **ENTER SET** to enter (screen 9). Press **▲** or **▼** to select memory 0-9 from the directory to store pre-programmed infusion rate and volume.
- 4) Press **ENTER SET** to confirm selection and enter (screen 10).
- 5) Press **▲** or **▼** to set the desired infusion rate, then press **ENTER SET** to confirm.
- 6) Press **▲** or **▼** to set the desired volume limit, then press **ENTER SET** to confirm and return to memory directory screen. Pre-programmed infusion combination will be stored in the memory.
- 7) Press **EXIT CLEAR** to return to MODE SETTING Screen 10 screen.
- 8) Press **EXIT CLEAR** again to return to main screen.

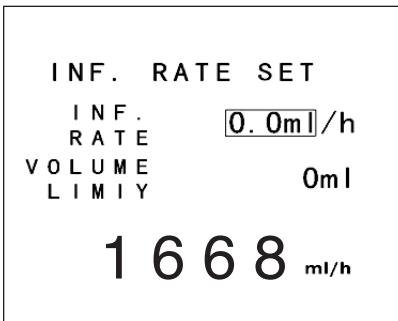

Screen 10

SLS Econoflow 84

Operation Settings and Procedures (Continued)





3. LANGUAGE SETTING



Screen 11



Screen 12

- 1) Press **MENU** to enter MODE SETTING screen.
- 2) Press  or  to select item No.2 **LANGUAGE**
- 3) Press **ENTER SET** into LANGUAGE SETTING menu. (screen 11)
- 4) Press  or  to select your preferred operation language (screen 11 & 12).
- 5) Press **ENTER SET** to confirm selection, and return to MODE SETTING screen.
- 6) Press **EXIT CLEAR** to return to main screen.

SLS Econoflow 84

Operation Settings and Procedures (Continued)

4. DATE FORMAT

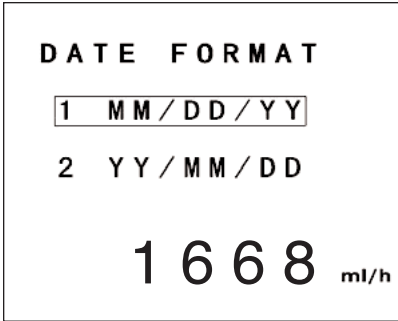

Screen 12

- 1) Press **MENU** to enter MODE SETTING status.
- 2) Press **↵** to item No.3 DATE FORMAT
- 3) Press **ENTER SET** to enter DATE FORMAT menu (screen 12). There are two choices of date format:
 - a. month/date/year: MM/DD/YY
 - b. year/month/date: YY/MM/DD
- 4) Press **ENTER SET** to confirm selection and return to MODE SETTING screen.
- 5) Press **EXIT CLEAR** return to main screen.

5. SET CLOCK

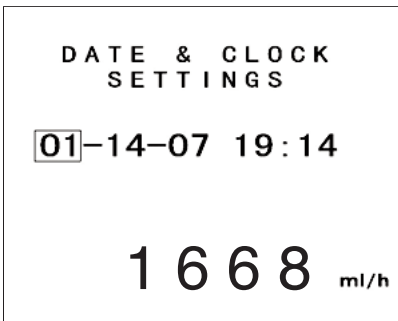

Screen 13

- 1) Press **MENU** to enter MODE SETTING status.
- 2) Press **↶** or **↷** to item No.4 SET CLOCK
- 3) Press **ENTER SET** to enter DATE & CLOCK SETTINGS menu. (screen 13)
- 4) Press **↶** or **↷** to set current date and time (24 hours).
- 5) Press **ENTER SET** to confirm selection, and back to MODE SETTING screen.
- 6) Press **EXIT CLEAR** to return to main screen.

SLS Econoflow 84

Operation Settings and Procedures (Continued)

6. DATE ON/OFF

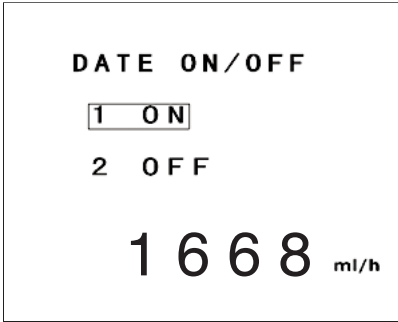

Screen 14

- 1) Press **MENU** to enter MODE SETTING status.
- 2) Press or to item No.5 DATE ON/OFF.
- 3) Press **ENTER SET** into DATE ON/OFF menu. (screen 14).
- 4) Press or to turn the date display which is on the main screen ON or OFF.
- 5) Press **ENTER SET** to confirm selection and return to MODE SETTING screen.
- 6) Press **EXIT CLEAR** to return to main screen.

7. ML OR DROP SETTING

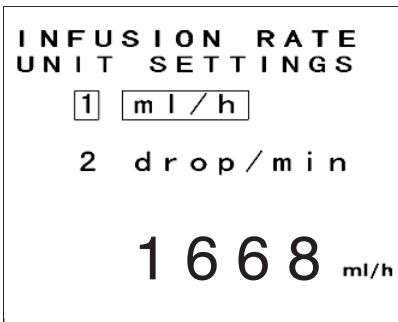

Screen 15

- 1) Press **MENU** to enter MODE SETTING status.
- 2) Press or to item No.6 ML OR DROPS.
- 3) Press **ENTER SET** to enter INFUSION RATE UNIT SETTINGS menu (screen 15).
- 4) Press or to choose infusion rate in ml/h or drop/min.

WARNING: Because the drop size of different fluid may vary, the infusion accuracy under drop/min mode is not as accurate as ml/h mode. It is recommended to use ml/h mode for most infusion applications to ensure the accuracy.

WARNING: Do **NOT** use the pump under drop/min mode in a mobile environment; the drip-chamber sensor can't count the drops properly in shaking or vibration status.

IMPORTANT: If drop/min is chosen for the infusion rate, the drip-chamber sensor **MUST** be connected to the pump and clamped on the drip chamber. **Note:** the sensor **MUST** be clamped above the liquid surface.

IMPORTANT: If drip-chamber sensor is not installed properly, infusion **CANNOT** start in drop/min mode, **DROP SENSOR NOT IN POSITION** (screen 16) message will be displayed.

SLS Econoflow 84

Operation Settings and Procedures (Continued)

7. ML OR DROP SETTING (Continued)

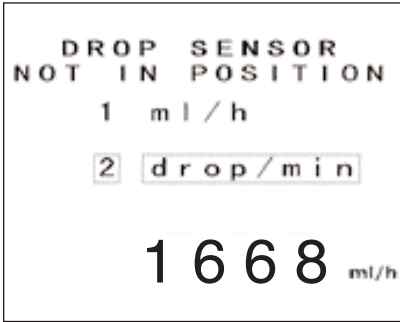

Screen 16

- 5) If **drop/min** is selected, press to enter the SELECT IV SET menu as shown on Screen 17 and Screen 18 for different IV set setting.
- 6) Please verify the IV set type on the IV set's packaging then press or to find the correct IV set setting.
- 6) Press to confirm selection and return to MODE SETTING screen.
- 7) Press to return to main screen

WARNING: Failure to select correct IV set will result inaccurate infused volume counting under **drop/min** mode.

IMPORTANT: Due to the design of the IV set, the minimum flow rate and maximum drop rate are varied for different IV set under **drop/min** mode, check the following conversion chart:

IV SET	Drop Rate Range	Equivalent Flow Rate
10 Drops/ml:	1/200 D/min	6/1200ml/h
15 Drops/ml:	1/200 D/min	4/800ml/h
20 Drops/ml:	1/200 D/min	3/600ml/h
60 Drops/ml:	1/180 D/min	1/180ml/h

IMPORTANT: For 60 Drops / ml IV set, the maximum drop rate is 1580 D/min; the maximum flow rate is 1580ml/h.

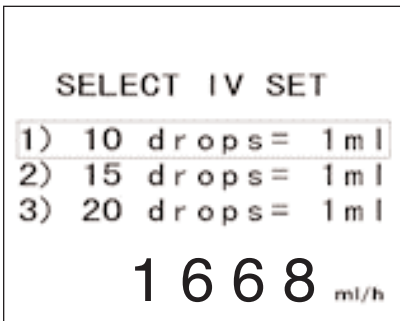

Screen 17

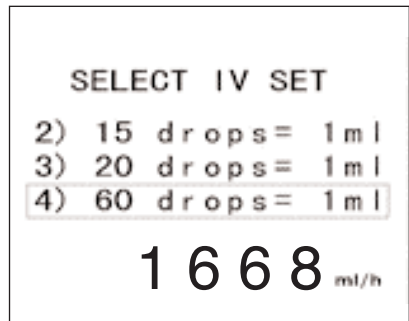

Screen 18

SLS Econoflow 84

Operation Settings and Procedures (Continued)

8. ADJ. I.V SET (ACCURACY CALIBRATION)

WARNING: THE ACCURACY OF THE PUMP HAS BEEN CALIBRATED TO THE IV SETS PACKAGED WITH THIS PUMP. The default setting is 0%. Other infusion sets should be prepared according to its accompanying instructions and user should adjust this IV pump's accuracy calibration according to manufacturer's recommendation.. **Failure to adjust the accuracy for other IV sets may result in an inaccurate infusion.**

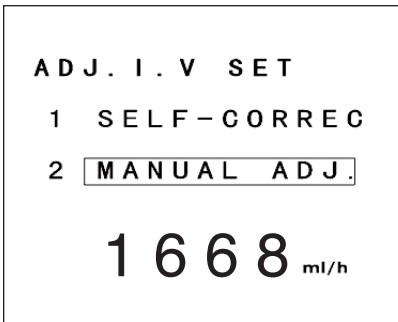

Screen 19

- 1) Press **MENU** to enter MODE SETTING status.
- 2) Press **⏏** to item No.7 **ADJ. I.V. SET.**
- 3) Press **ENTER SET** to enter ADJ. I.V SET menu (Screen 19). There are two options for accuracy calibration:

SELF-CORRECTION (For drop/min mode ONLY) If the self-correction function is selected to calibrate the accuracy automatically, the drip-chamber sensor **MUST** be connected to the pump and clamped on the drip chamber. The **SELF-CORRECTION ONLY** works under drop/min mode; it will adjust the drop rate automatically according to the preset drop rate. The **SELF-CORRECTION DOES NOT** work under ml/hr mode, the pump will **NOT** adjust the flow rate automatically.

IMPORTANT: If drip sensor was not installed properly, self-correction function will not start.

SLS Econoflow 84

Operation Settings and Procedures (Continued)

8. ADJ. I.V SET (ACCURACY CALIBRATION Continued)

MANUAL ADJUSTMENT (For ml/h or drop/min mode)

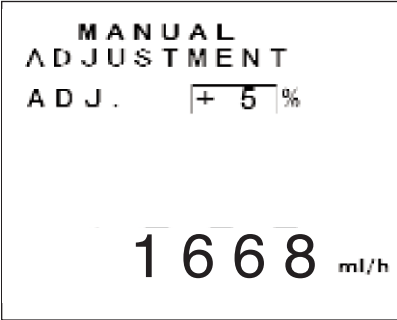

Screen 20

- 1) Press to choose manual calibration. (screen 20)
- 2) Press or to change calibration volume in percentage.
- 3) Press to confirm the adjustment and return to the MODE SETTING status.

IMPORTANT : The manual adjustment is in effect at the current flow rate from 0.1 to 1000 ml/hr ONLY. The pump will NOT respond to the manual adjustment if the current flow rate is set from 1001 to 1200 ml/hr.

SLS Econoflow 84

Operation Settings and Procedures (Continued)

9. OCCLU. LEVEL (OCCLUSION LEVEL)

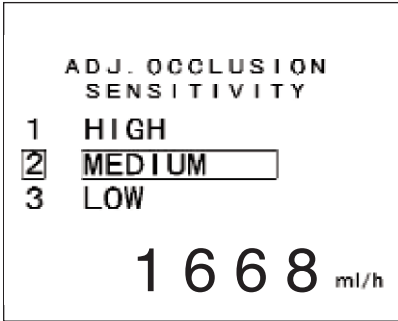

Screen 21

- 1) Press **MENU** to enter MODE SETTING status.
- 2) Press **⇩** to item No.8 **OCCLU. LEVEL (OCCLUSION LEVEL)**.
- 3) Press **ENTER SET** to enter ADJ. OCCLUSION SENSITIVITY menu (screen 21 and screen 22). There are 4 levels of occlusion sensitivity to adjust:

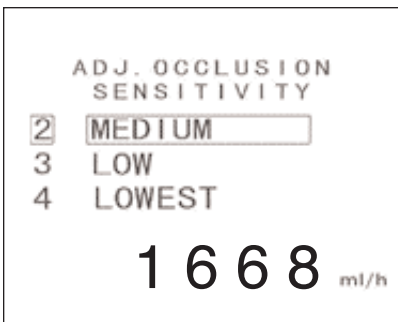

Screen 22

HIGH: If the pump is not sensitive enough to trigger occlusion alarm with certain I.V sets, **HIGH** occlusion sensitivity level should be selected.

MEDIUM: **MEDIUM** occlusion sensitivity level is the factory default setting. This occlusion sensitivity level is preferred for most scenarios.

LOW: If the pump is too sensitive enough to trigger occlusion alarm, **LOW** occlusion sensitivity level shall be selected.

LOWEST: If the pump is still too sensitive and frequently sets off occlusion alarm with other I.V sets, **LOWEST** occlusion sensitivity level shall be selected.

WARNING: The occlusion alarm will not be triggered under **LOWEST OCCLUSION SENSITIVITY LEVEL** for most pump use IV sets.

SLS Econoflow 84

Operation Settings and Procedures (Continued)

10. FACTORY RESET



Screen 23

- 1) Press to enter MODE SETTING status.
- 2) Press or to select item No.9 FACTORY RESET.
- 3) Press to enter FACTORY RESET menu. (Screen 23).
- 4) Select CONFIRM, press to reset the pump.

WARNING: Once pump is reset, all settings will return to factory default as following:

- 1) All preset data and pre-programmed infusion modes will be cleared.
- 2) The occlusion level will be reset to medium.
- 3) The accuracy calibration will be reset to 0%
- 4) The current date & time will be kept.

SLS Econoflow 84



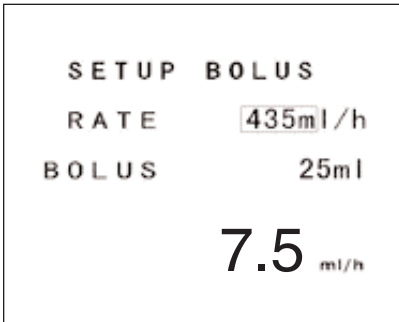





Bolus Function



Screen 24



Screen 25

- 1) During normal infusion, an additional dose of medication can be infused into patient by holding  button. BOLUS dosage can be preset by holding  for 2 seconds to enter SETUP BOLUS (screen 24) menu.
- 2) Press  or  to set preferred BOLUS RATE in ml/h then press  to confirm the rate setting.
- 3) Press  or  to set preferred BOLUS VOLUME in ml. Minimum bolus volume is 1 ml; maximum bolus volume is 9999 ml. Press  to confirm the volume setting.
- 4) Pump will remind the user by asking "BOLUS?", (Screen 25).
- 5) Press  to confirm bolus setting.

IMPORTANT: There will be no interruption for current infusion during the BOLUS setup.

WARNING: If the Bolus volume exceeds the remaining volume to be infused on main setup screen, the pump will display 'BOLUS TOO MUCH!' and return to the main screen. The current bolus setup will be cancelled!

SLS Econoflow 84

Bolus Function (Continued)

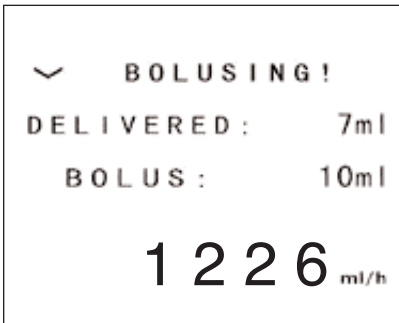

Screen 26

- 5) To start a bolus, press **PURGE BOLUS**. Bolus infusion will start at the preset rate and volume. Bolus screen will appear (screen 26) to remind user of the delivered bolus volume. Once the delivered bolus volume reaches the preset bolus volume, the pump will automatically switch back to the current infusion rate; normal infusion will continue.

WARNING: BOLUS volume will be added into TOTAL VOLUME DELIVERED.

The preset bolus infusion rate and volume will be kept in the memory of the pump. If the user wants to restart the same bolus infusion, please hold **PURGE BOLUS** for 2 seconds to enter **SETUP BOLUS** screen, then press **ENTER SET** twice, and start the same bolus by pressing **PURGE BOLUS** once.

SLS Econoflow 84

Purge Function

WARNING: The IV set must be disconnected from the patient before purging. After the purging is complete, the user can connect the IV set to the patient again. NEVER use purge while the IV set is still connected with the patient.

While the pump is stopped, user can purge the IV set by holding  to purge the I.V set. This is for clearing the occlusion or air-in-line conditions.

IMPORTANT: The purge rate is **1200 ml/h**. PURGE volume will not be counted into VOLUME DELIVERED.

SLS Econoflow 84

Alarm Messages

1. START REMINDER ALARM

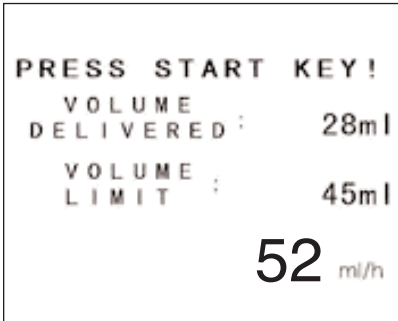

Screen 27

If all the necessary settings for a regular infusion are completed but user did not start the infusion within 3 minutes, audible alarm will sound with a visual flashing warning light on top. The pump will remind user to **PRESS START KEY!** (screen 27)

2. DOOR OPEN ALARM

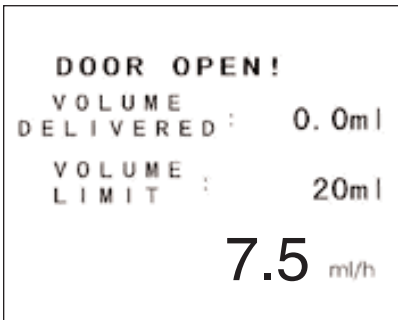

Screen 28

If the door is accidentally opened during a regular infusion, the pump stops infusion immediately with audible alarm and visual flashing warning light on top to remind user of **DOOR OPEN!** (screen 28)

IMPORTANT: If the door is opened when the pump is not running, the screen will display **DOOR OPEN!** (screen 28) message without audible and visual alarms.

SLS Econoflow 84

Alarm Messages (Continued)

3. AIR IN LINE ALARM

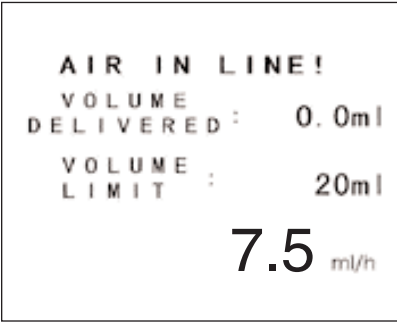

Screen 29

If air bubble is detected in the I.V set during a regular infusion, AIR IN LINE alarm will be triggered with an audible and visual flashing light. (screen 29) The pump will stop regular infusion and switch to a KVO (Keep Vain Open) infusion mode. Press **EXIT CLEAR** key to silence the alarm buzzer. Infusion can be resumed ONLY after the AIR IN LINE condition is cleared.

4. OCCLUSION IN LINE

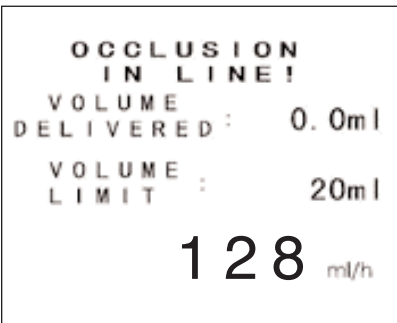

Screen 30

If occlusion occurs in the I.V set or in the needle area during a regular infusion, **OCCLUSION IN LINE** alarm will be triggered with an audible alarm and visual flashing light. (screen 30) Infusion can be resumed ONLY when the OCCLUSION condition is cleared.

5. EMPTY ALARM

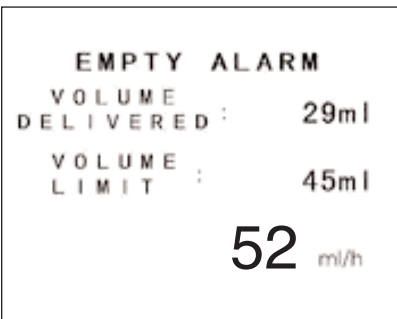

Screen 31

During a regular infusion, while there is no medication left, an **EMPTY ALARM** will be triggered to remind the user of an empty medication reservoir. (screen 31)

SLS Econoflow 84

Alarm Messages (Continued)

5. EMPTY ALARM (Continued)

IMPORTANT: The **EMPTY ALARM** can only be triggered when the drop sensor is plugged in; The EMPTY ALARM will be triggered only if there are no drops going through the drip chamber.

WARNING: There are three situations that may trigger the EMPTY ALARM if drop sensor is used:

- a. Medication in the reservoir is finished;
- b. Drip sensor is not properly plugged into the pump and/or clamped on the drip-chamber;
- c. Drip sensor is removed from the drip-chamber; in the above three situations, EMPTY ALARM will be triggered with an audible and visual flash light.

Pump will stop regular infusion and switch to a KVO (Keep Vain Open) infusion mode. Press to silence the alarm buzzer.

IMPORTANT: Infusion can be resumed ONLY after the EMPTY condition is cleared.

6. COMPLETE ALARM

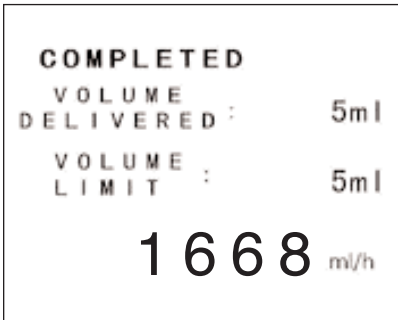

Screen 32

During a regular infusion, when the VOLUME DELIVERED matches the VOLUME LIMIT (volume to be infused), **COMPETED** alarm will be triggered with audible alarm and visual flash light. (screen 32) Pump will stop regular infusion and switch to a KVO (Keep Vain Open) infusion mode (KVO rate is 0.1 ml/h at micro infusion; 1 ml/h or 2 ml/h at macro infusion). User can press to silence the alarm buzzer.

IMPORTANT: To restart or clear the total infused volume, press ON/OFF switch on the back of the pump. After the pump is turned OFF, user must wait at least 3 seconds to turn on the pump again.

SLS Econoflow 84

Alarm Messages (Continued)

7. LOW BATTERY ALARM

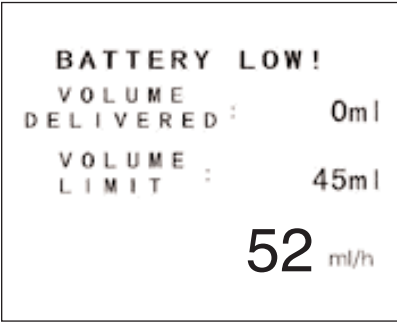

Screen 33

WARNING: If **BATTERY LOW ALARM** is triggered, user must connect pump into a electrical outlet immediately to work under plug-in power and charge the internal batteries. Failure to do that may cause the pump working abnormally and result serious injury to the patient!

If battery power is low while pump is operated with internal battery power supply, **BATTERY LOW ALARM** will be triggered with audible alarm and visual flash light. (screen 33)

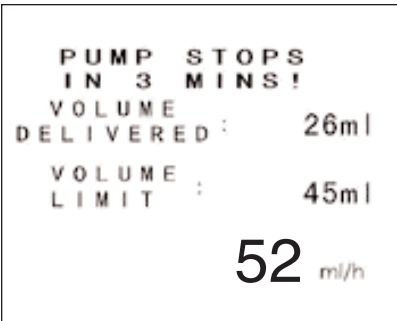

Screen 34

When the **BATTERY LOW ALARM** is triggered for the first time, pump will continue operating for a while depending on the current infusion rate. User **MUST** connect the pump to the electrical outlet immediately. If pump is not connected into an electrical outlet within 30 minutes, **PUMP STOPS IN 3 MINS** alarm will be displayed on the screen (screen 34) with audible alarm and visual flash light. Pump will stop in 3 minutes after the 3-minutes alarm is triggered.

SLS Econoflow 84

Alarm Messages (Continued)

8. DRIVE MECHANISM ERROR



Screen 33

If a mechanism error is detected during an infusion, **DRIVE MECHANISM ERROR** alarm will be triggered. Pump will stop infusion and display error message on the screen. (screen 33) . Once this message is displayed, the user should disconnect the IV set with patient immediately. Then press ON/OFF switch on the back of the pump to turn off the pump completely.

IMPORTANT: If the battery depleted alarm is displayed. The pump's drive can't work properly. The **DRIVE MECHANISM ERROR** alarm will be triggered in this case. However, the user can clear this alarm by connecting the pump to electrical outlet and make sure the power indicator on the front of the pump is green. Wait for 30 seconds. Then press ON/OFF switch on the back of the pump to turn on the pump again.

WARNING: If the **DRIVE MECHANISM ERROR** alarm still appears in the start up procedures, pump will not finish the normal operation. Pump cannot be used anymore unless inspected by authorized service personnel!

SLS Econoflow 84

Limited Warranty

Scientific Lab Supply Inc. warrants to the first consumer purchaser, for a period of one year from the date of purchase that this unit, when shipped in its original container, will be free from defective workmanship and materials and agree that it will, at its option, either repair or replace the defective unit.

This warranty does not extend to misuse, neglect or abuse, normal wear and tear, accident, modification or unauthorised repair.

Scientific Lab Supply will not be liable or in any way responsible for any incidental or consequential economic or property damage. Some States do not allow the exclusion of incidental or consequential damages, so the above exclusion may not apply to you.

There are no implied warranties of merchantability, or fitness for a particular use, or of any other nature. Some states do not allow this limitation on implied warranty, so the above limitation may not apply to you.

If a defect arises within the warranty period contact Scientific Lab Supply Inc., (see address below).

The customer is responsible for shipping charges and must first obtain a Return Material Authorization number (RMA) before the unit will be accepted. If a replacement unit is issued it is covered only for the remainder of the original warranty period dating from the purchase of the original device.

This warranty gives you specific legal rights. You may also have other rights which vary from state to state.

Note: This pump is not registered with the FDA and is not for clinical use on patients.

Scientific Lab Supply,

6 Chestnut Street

Acton, MA 01720

Phone: 978.821.1187

E-mail: scientificlab@aol.com

Web: www.scientificlabsupply.com

